

ALL MODELS 750-1150  
 PORT SIDE  
 COMPATIBLE WITH MERCURY 280S AND 380S BOLT PATTERN  
 SCALE 1:1

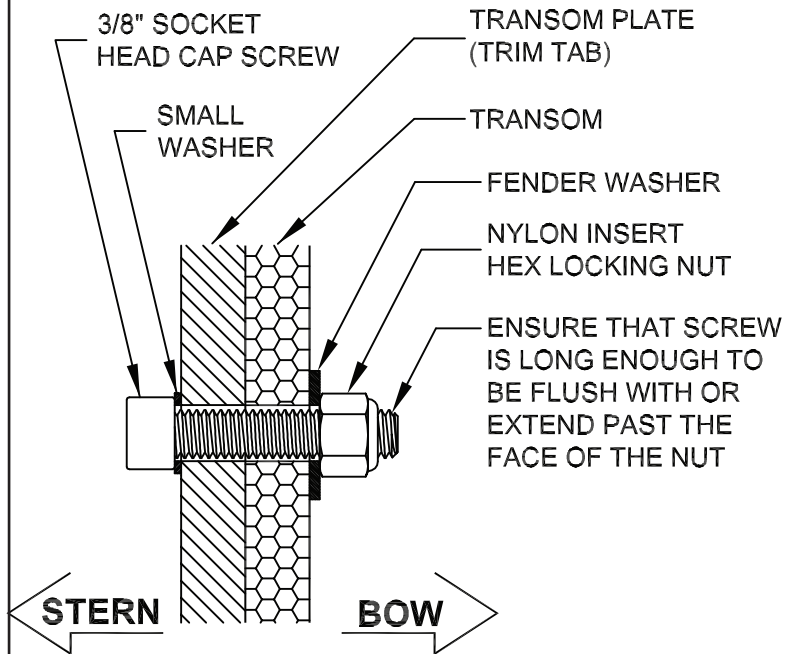

TYPICAL FASTENER INSTALLATION

**MUST BE PRINTED ON 15"X19" SIZE PAPER OR LARGER**

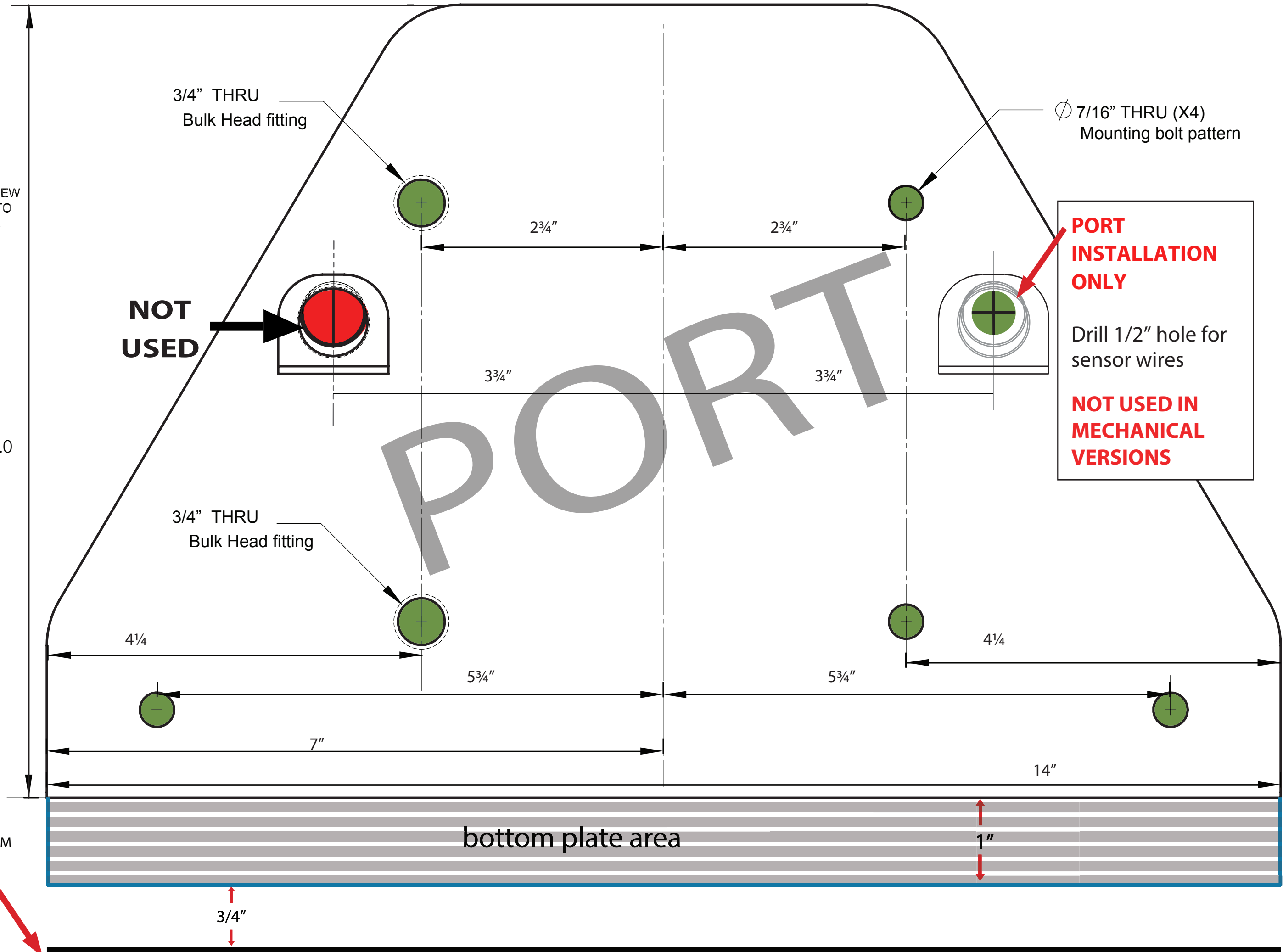

ALL MODELS 750-1150  
 STARBOARD SIDE  
 COMPATIBLE WITH MERCURY 280S AND 380S BOLT PATTERN  
 SCALE 1:1

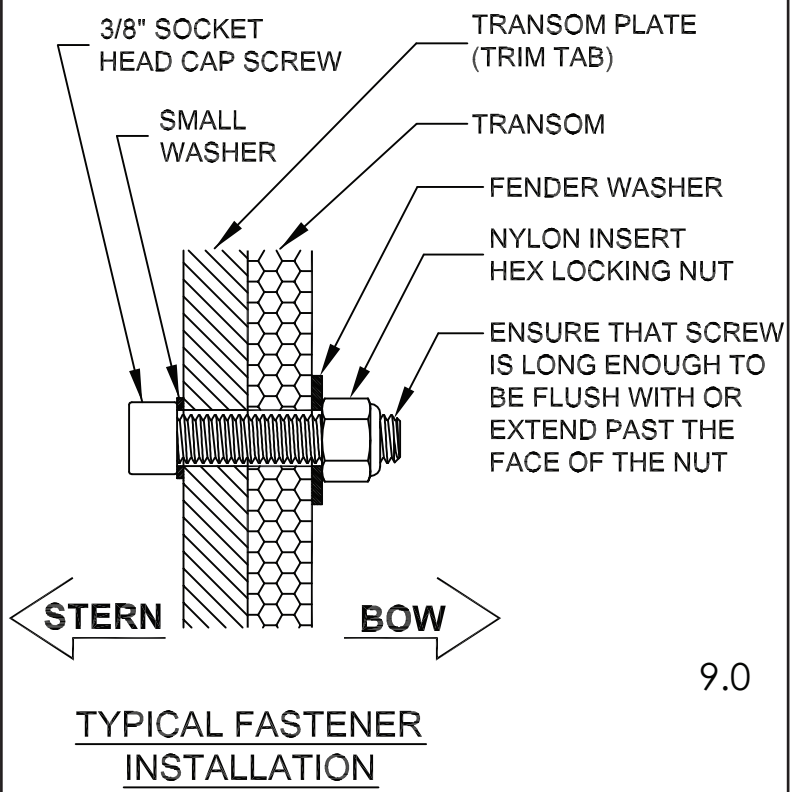

**MUST BE PRINTED ON 15"X19" SIZE PAPER OR LARGER**

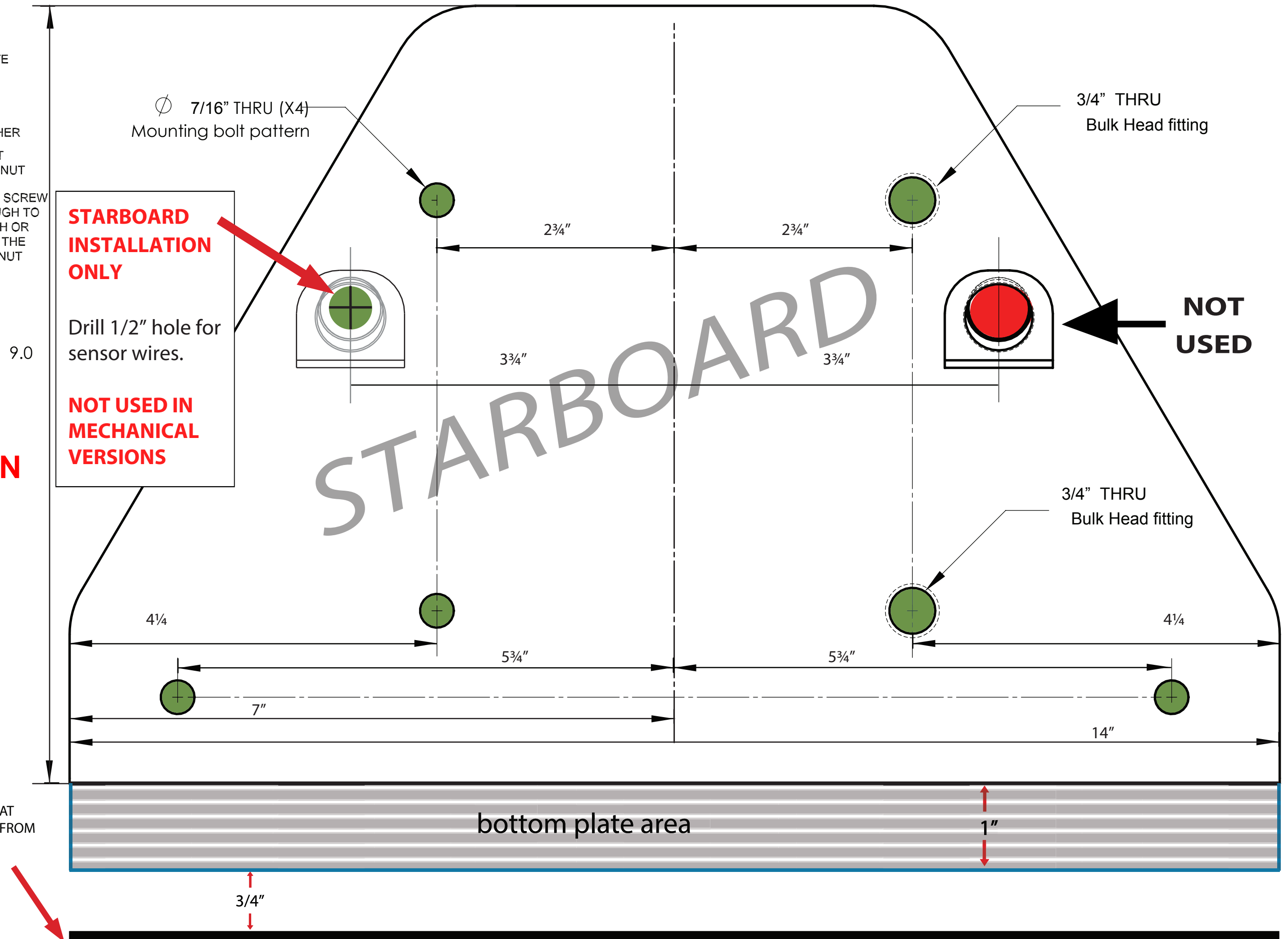

**STARBOARD INSTALLATION ONLY**

Drill 1/2" hole for sensor wires.

**NOT USED IN MECHANICAL VERSIONS**

LINE UP WITH THE BOTTOM OF THE BOAT FOR RECOMMENDED SETTING OF 3/4" FROM LOWER TRIM PLATE TO BOAT BOTTOM