

LED Navigation Light
Port or Starboard
Model #'s LEDNL2G, LEDNL2R or LEDNL2W

Installation Instructions

1. These lights are designed to be mounted on a vertical surface 24 degrees relative to the boat's centerline so that the light pattern is unobstructed. International Navigation Rules require that sidelights be installed above the uppermost continuous deck, i.e. above the vessel's rub rail.

See reverse of this page for proper mounting angles. Or you may refer to the ABYC Standard A-16, '72 COLREG, and the U.S. Inland Navigation Rules for proper light, location & positioning.

2. Connect 12V power to the red wire and ground to the black wire.

- USCG Approval 33 CFR 183.810
- USCG-2NM
- Meets ABYC -16
- NMMA Type Accepted Equipment
- Tested at Imanna Lab Inc.
- Certified for 2 miles
- Certified for vessels up to 20 meters in length
- Type Tested on January 23, 2008

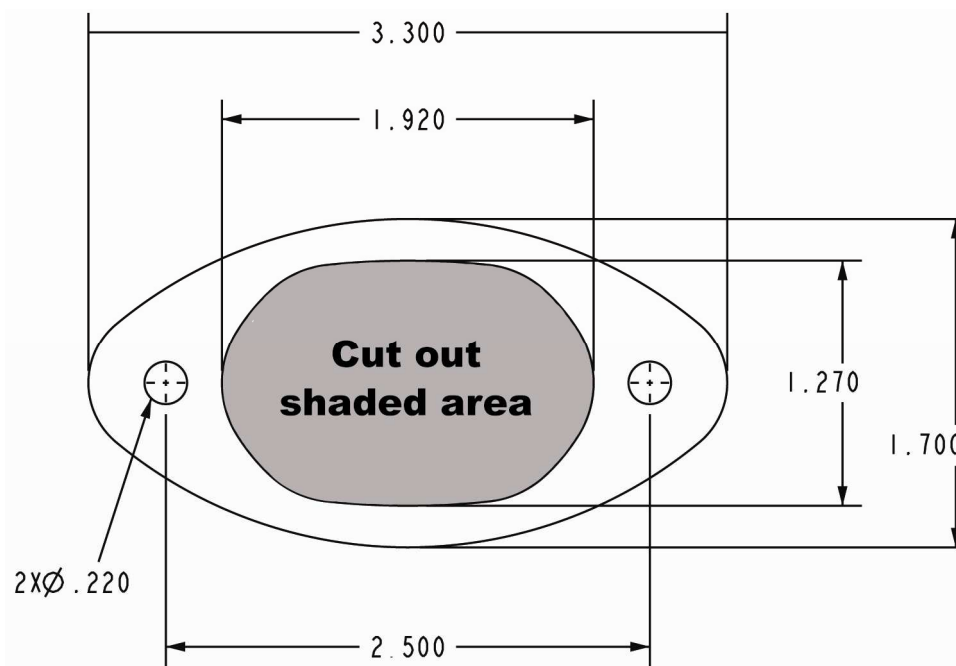

Navigation Sidelights

ABYC SECTION A-16:
Sidelights - The starboard sidelight showing green, and the port sidelight showing red, from dead ahead to 22.5° abaft the beam ($90^\circ + 22.5^\circ = 112.5^\circ$) on their respective sides.

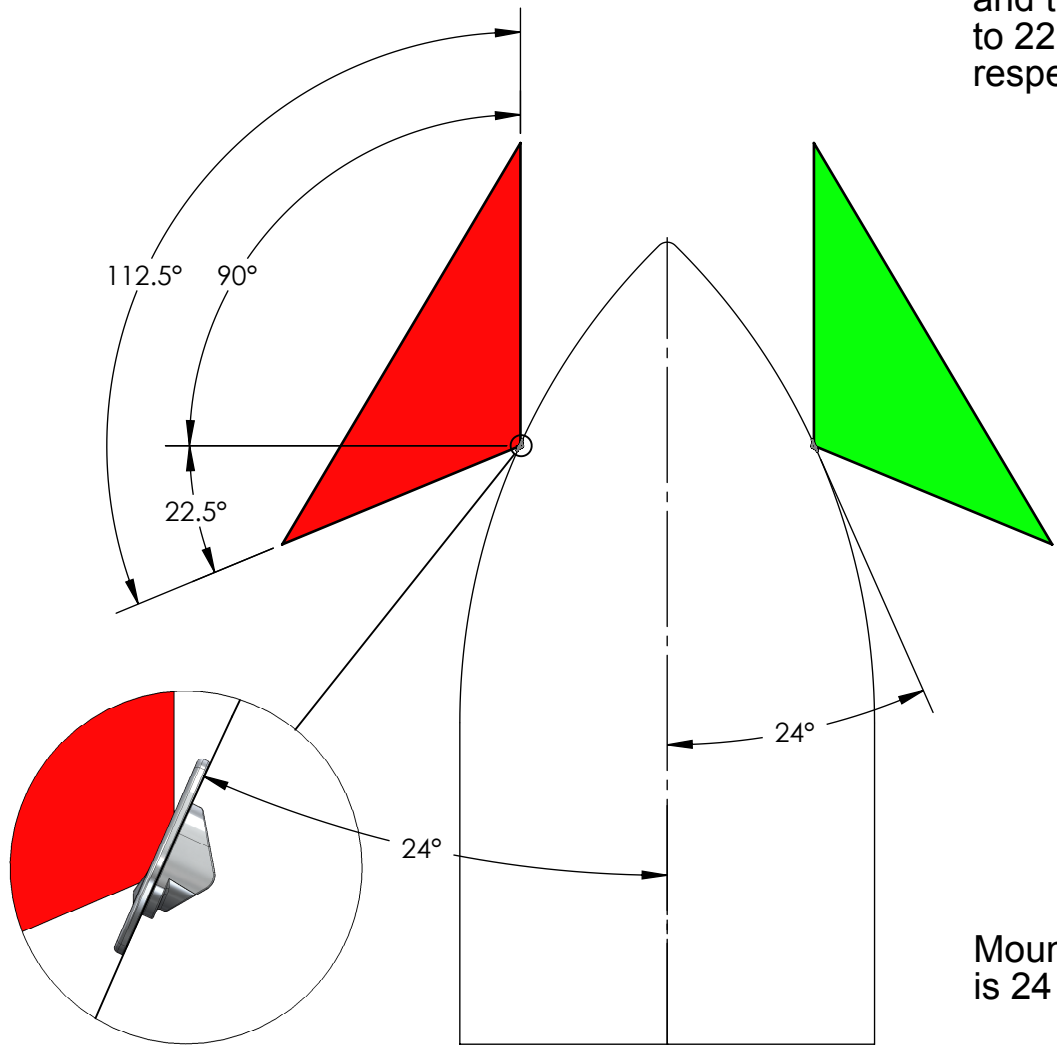

Mounting angle for Livorsi Navigation Light is 24° relative to centerline of boat.



GRAYSLAKE, ILL

THE INFORMATION ON THIS DRAWING IS PROPRIETARY TO LIVORSI MARINE. ALL UNAUTHORIZED USE IS PROHIBITED.

NAVIGATION SIDELIGHTS
MOUNTING REFERENCE

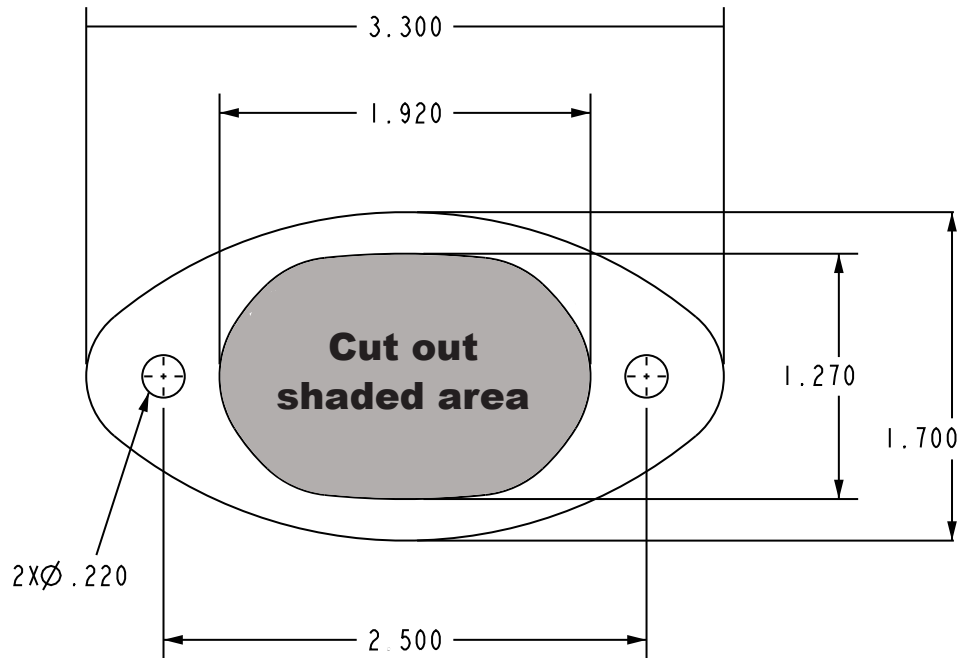
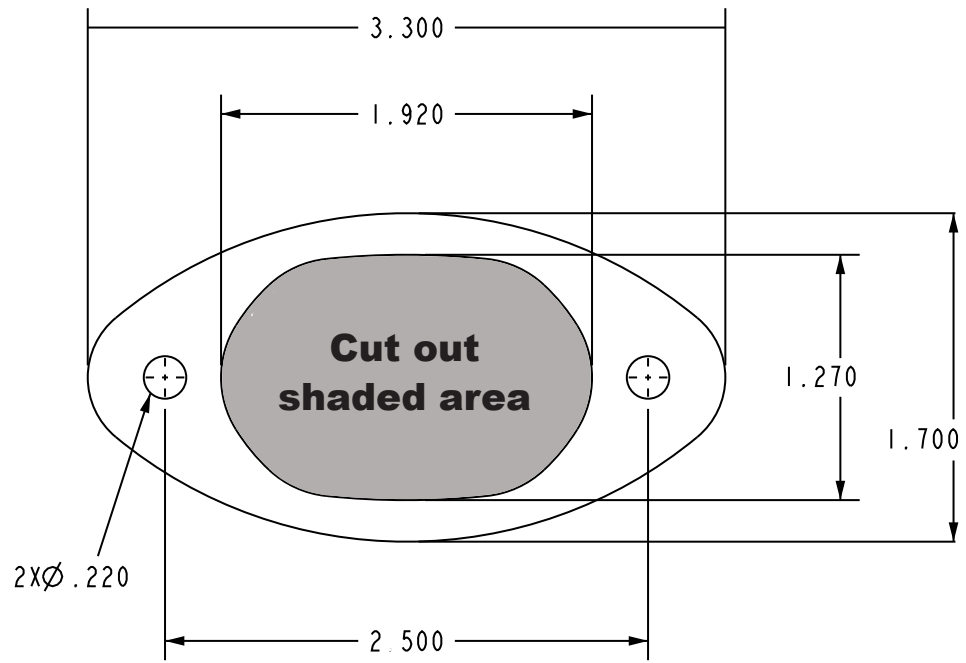

LEDNLG- LEDNLR CUTOUT TEMPLATE